

# Keystone Retaining Wall System with Manta Ray Earth Anchors

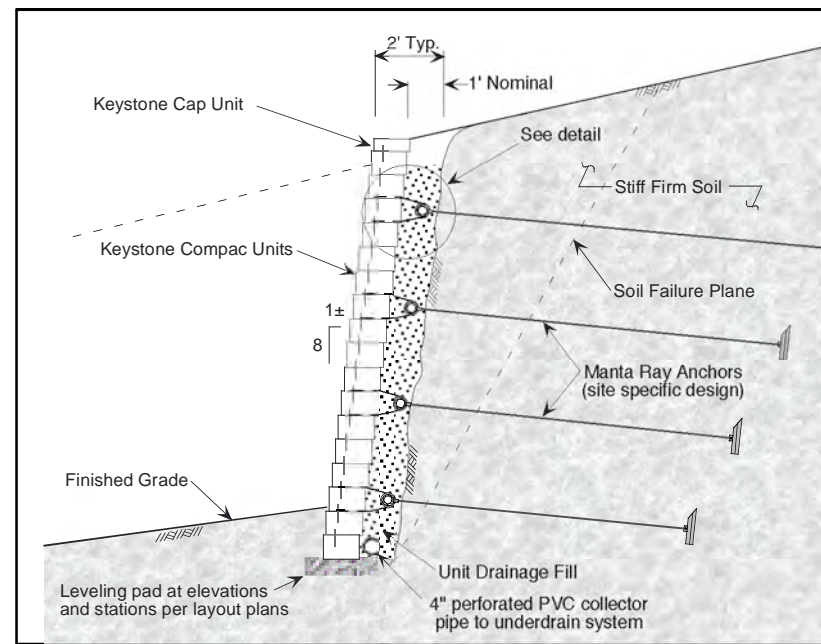

MR-3

MR-2

MR-1



DRAWING INDEX	
Title Sheet	Sheet 1
Anchor Facing Details	Sheet 2
Keystone/Manta Design	Sheet 3
Keystone/Manta Design	Sheet 4
Keystone/Manta Details	Sheet 5
General Specifications	Sheet 6

COPYRIGHT (c) 2000 by Keystone Retaining Wall Systems, Inc.

The information contained herein has been compiled by Keystone Retaining Wall Systems and to the best of our knowledge, accurately represents the Keystone product use in the applications which are illustrated. This drawing is being furnished for design guidance and estimating only. Final determination of the suitability for the use contemplated and its manner of use are the sole responsibility of the user. Structural and geotechnical design analysis shall be performed by a qualified engineer.

Any party accepting this document does so in confidence and agrees that it shall not be duplicated in whole or in part, nor disclosed to others without the consent of Keystone Retaining Wall Systems, Inc.

No.	Date	Revision	By



Designed By: cdm	Keystone/Manta Ray Wall	Title Sheet	
Checked By:			
Date: 6/29/00	Scale:	Project No:	Drawing No. 1

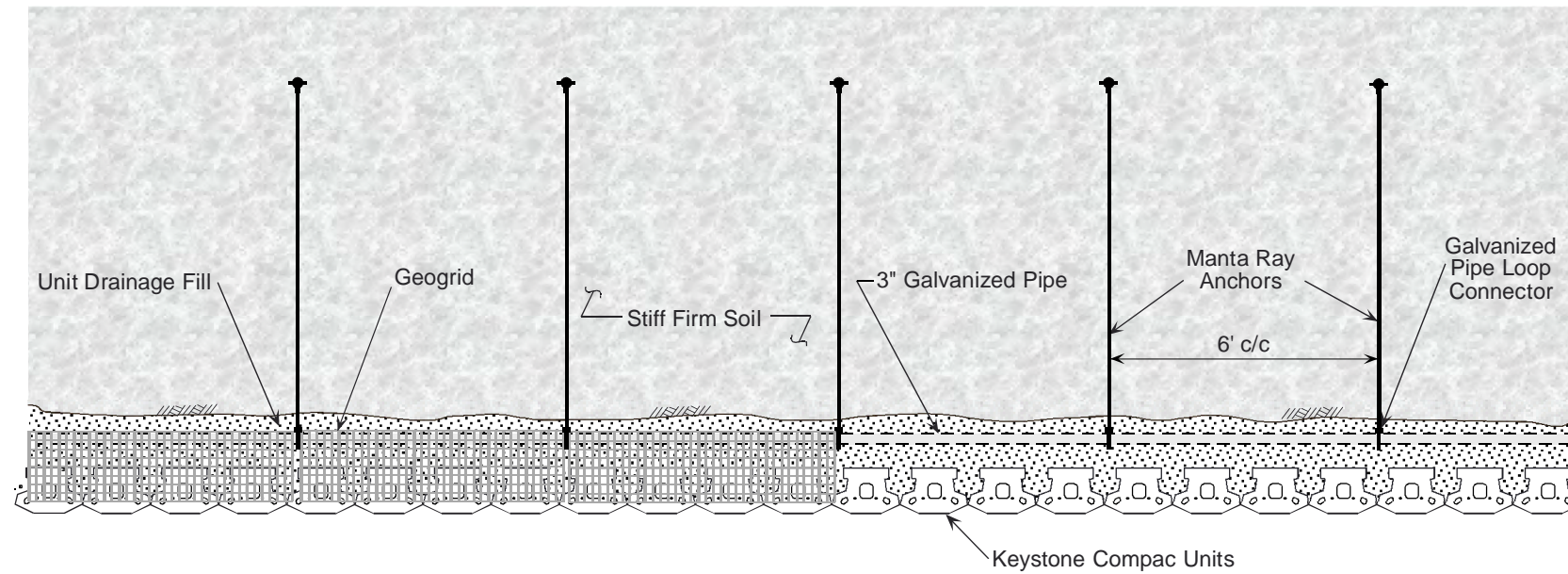

Typical Plan View

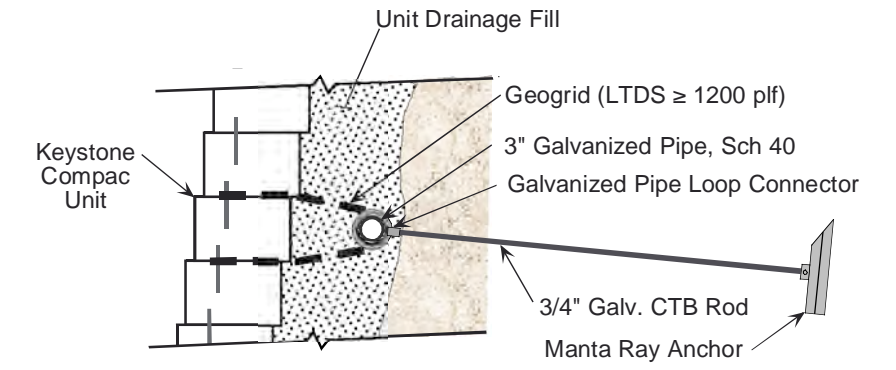

Typical Detail

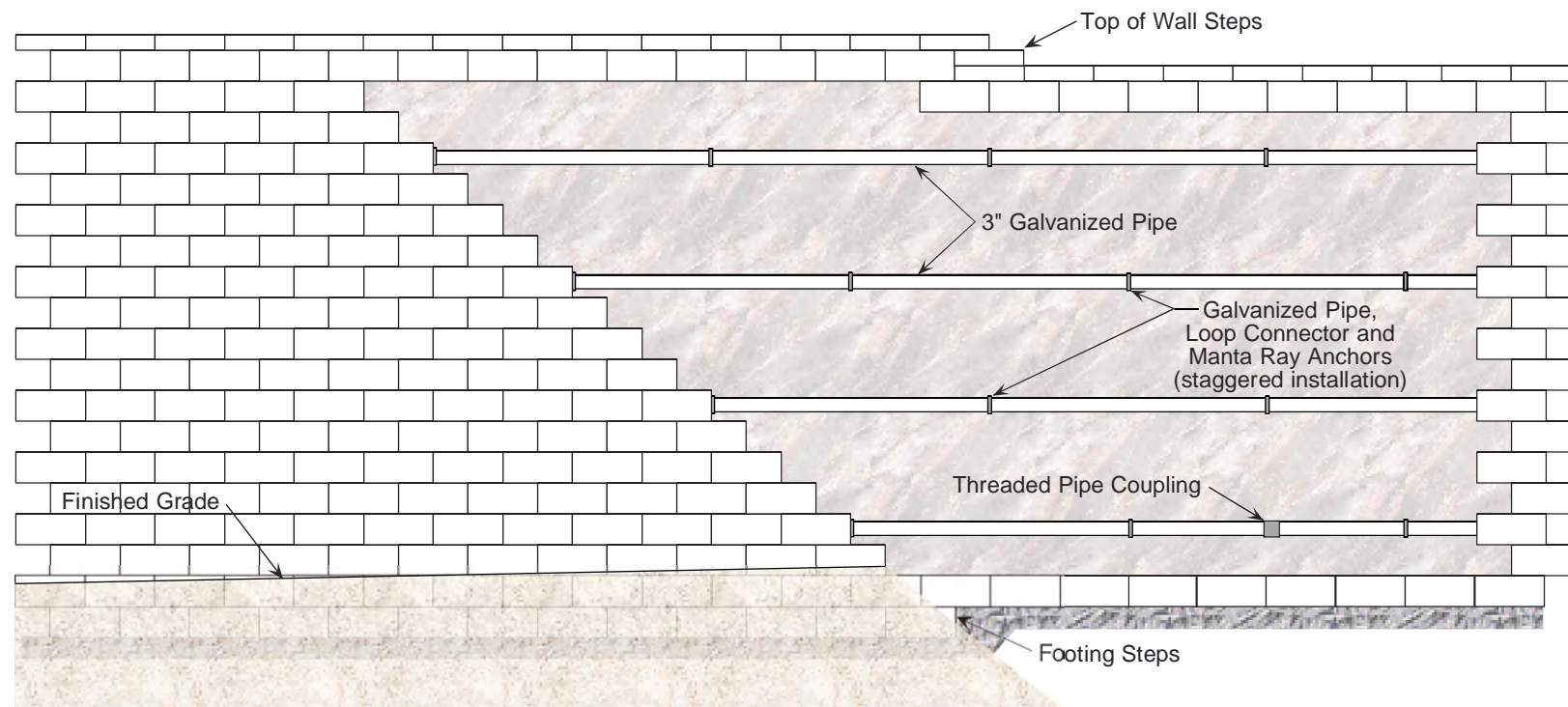

Typical Wall Elevation

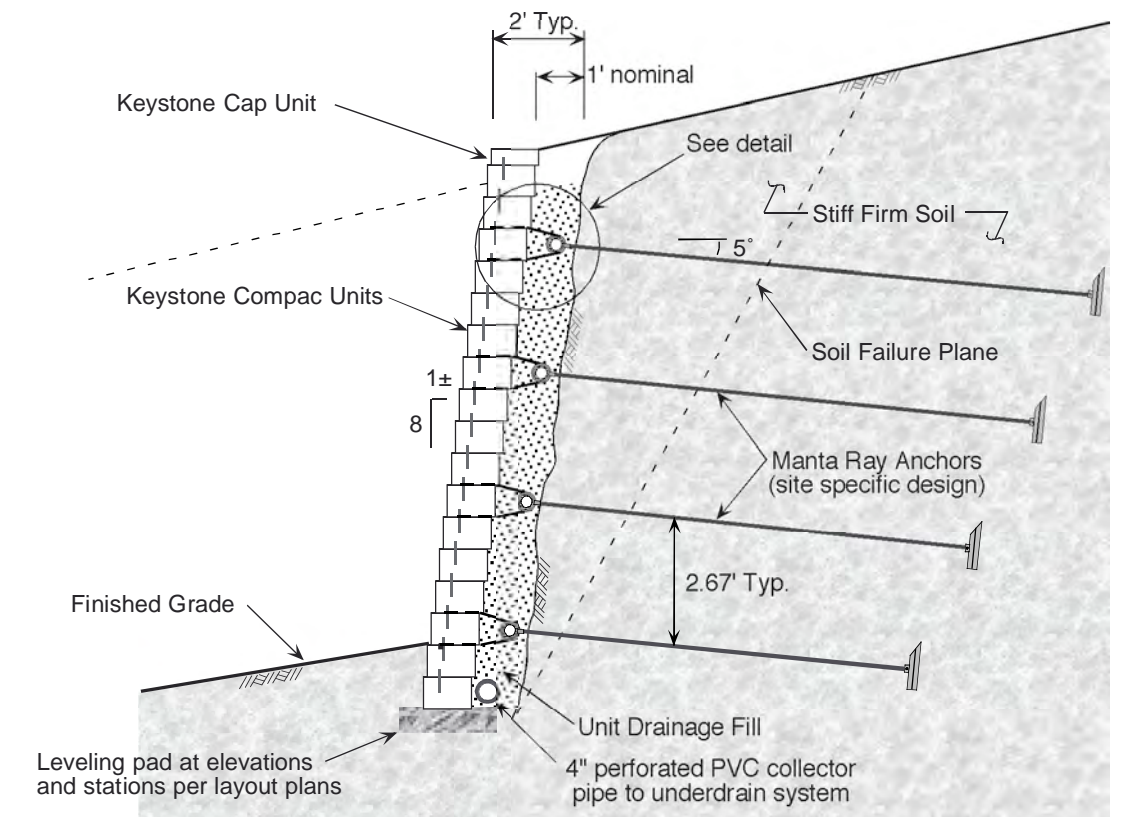

Typical Manta Ray Anchor Section

COPYRIGHT (c) 2000 by Keystone Retaining Wall Systems, Inc.

The information contained herein has been compiled by Keystone Retaining Wall Systems and to the best of our knowledge, accurately represents the Keystone product use in the applications which are illustrated. This drawing is being furnished for design guidance and estimating only. Final determination of the suitability for the use contemplated and its manner of use are the sole responsibility of the user. Structural and geotechnical design analysis shall be performed by a qualified engineer.

Any party accepting this document does so in confidence and agrees that it shall not be duplicated in whole or in part, nor disclosed to others without the consent of Keystone Retaining Wall Systems, Inc.

No.	Date	Revision	By



Designed By:  
cdm

Checked By:

Date:  
6/29/00

Keystone/Manta Ray Wall

Manta Ray Anchor Facing

Scale:

Project No:

Drawing No.

2

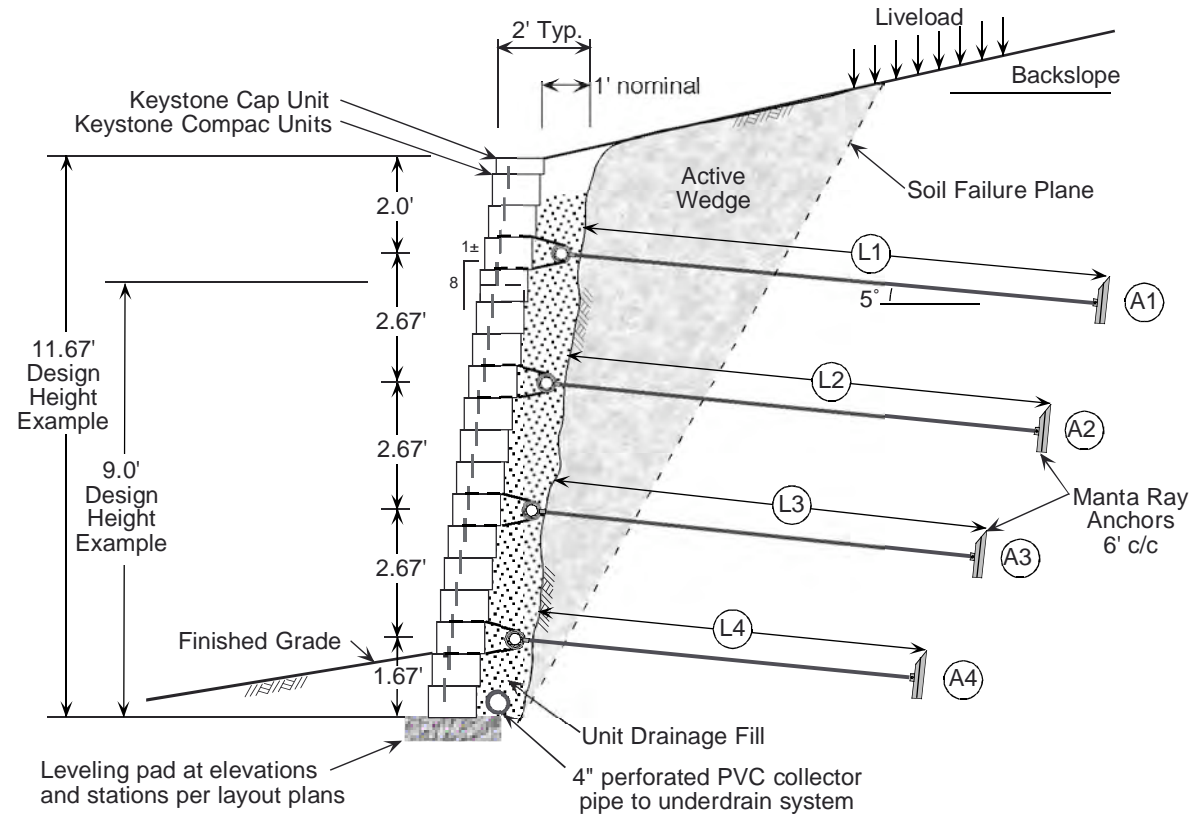

Typical Keystone/Manta Ray Anchor Section

**Manta Ray Anchor Systems**  
Peak Holding Capacity Range in Kips  
(Design Value = Range Ave/1.5)

Common Soil Type Description	"N" SPT Blow Count Per Foot	Manta Ray Anchor Designation					
		MR-3		MR-2		MR-1	
		Peak	Design	Peak	Design	Peak	Design
A) Loose Fine Sands, Alluvium; Soft Clays Varied Clays, Fill	4 - 8	3-5K	2K	5-8K	4K	8-12K	6K
B) Loose to Medium Dense Fine to Coarse Sands; Firm to Stiff Silts and Clays	7 - 14	5-8K	4K	7-10K	5K	10-15K	8K
C) Med Dense Coarse Sand and Sandy Gravel; Stiff to Very Stiff Silts and Clays	14 - 25	7-9K	5K	9-12K	7K	15-20K	11K

- Assumed design value is peak capacity range average divided by FS=1.5
- Test anchors shall be proofloaded to failure in actual site soils to confirm peak holding capacity.
- Anchors shall be proofloaded or "locked" to their design load to validate each soil/anchor capacity.
- All manufacturer's installation recommendations of Manta Ray by Foresight Products shall be followed.

**Typical Keystone/Manta Ray Anchor Sizing and Lengths**

**11.67' Design Height Example**

Minimum Anchor Lengths			
Designation	A-Soil	B-Soil	C-Soil
L1	13'	13'	12'
L2	12'	12'	11'
L3	10'	10'	10'
L4	8'	8'	8'

Minimum Anchor Sizes			
Level Backslope			
Designation	A-Soil	B-Soil	C-Soil
A1	MR-3	MR-3	MR-3
A2	MR-2	MR-3	MR-3
A3	MR-1	MR-3	MR-3
A4	MR-1	MR-2	MR-3

Level - 250 psf Surcharge			
Designation	A-Soil	B-Soil	C-Soil
A1	Requires Site Specific Analysis	MR-3	MR-3
A2		MR-2	MR-3
A3		MR-1	MR-3
A4		MR-1	MR-2

3H:1V Backslope			
Designation	A-Soil	B-Soil	C-Soil
A1	MR-3	MR-3	MR-3
A2	MR-2	MR-3	MR-3
A3	MR-1	MR-2	MR-3
A4	MR-1	MR-1	MR-2

**9.0' Design Height Example**

Minimum Anchor Lengths			
Designation	A-Soil	B-Soil	C-Soil
L1	-	-	-
L2	12'	12'	11'
L3	10'	10'	10'
L4	8'	8'	8'

Minimum Anchor Sizes			
Level Backslope			
Designation	A-Soil	B-Soil	C-Soil
A1	-	-	-
A2	MR-3	MR-3	MR-3
A3	MR-2	MR-3	MR-3
A4	MR-1	MR-3	MR-3

Level - 250 psf Surcharge			
Designation	A-Soil	B-Soil	C-Soil
A1	Requires Site Specific Analysis	-	-
A2		MR-3	MR-3
A3		MR-2	MR-3
A4		MR-1	MR-3

3H:1V Backslope			
Designation	A-Soil	B-Soil	C-Soil
A1	-	-	-
A2	MR-3	MR-3	MR-3
A3	MR-2	MR-3	MR-3
A4	MR-1	MR-2	MR-3

A-Soil --  $\phi = 26^\circ$  and  $\gamma = 120$  pcf assumed  
 B-Soil --  $\phi = 30^\circ$  and  $\gamma = 120$  pcf assumed  
 C-Soil --  $\phi = 34^\circ$  and  $\gamma = 120$  pcf assumed

COPYRIGHT (c) 2000 by Keystone Retaining Wall Systems, Inc.

The information contained herein has been compiled by Keystone Retaining Wall Systems and to the best of our knowledge, accurately represents the Keystone product use in the applications which are illustrated. This drawing is being furnished for design guidance and estimating only. Final determination of the suitability for the use contemplated and its manner of use are the sole responsibility of the user. Structural and geotechnical design analysis shall be performed by a qualified engineer.

Any party accepting this document does so in confidence and agrees that it shall not be duplicated in whole or in part, nor disclosed to others without the consent of Keystone Retaining Wall Systems, Inc.

No.	Date	Revision	By



Designed By:  
cdm

Checked By:

Date:  
6/29/00

Keystone/Manta Ray Wall

Scale:

Keystone/Manta Ray Design

Project No:

Drawing No.

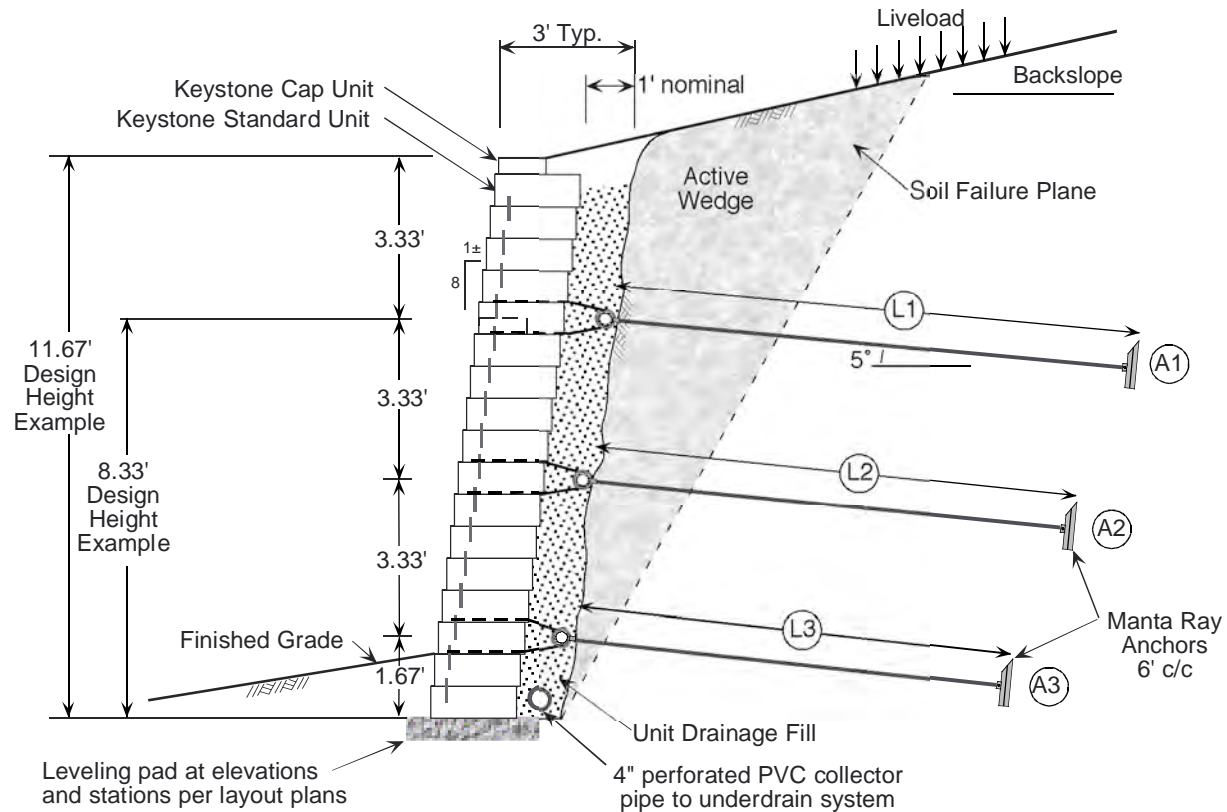

Typical Keystone/Manta Ray Anchor Section

**Manta Ray Anchor Systems**  
Peak Holding Capacity Range in Kips  
(Design Value = Range Ave/1.5)

Common Soil Type Description	"N" SPT Blow Count Per Foot	Manta Ray Anchor Designation					
		MR-3		MR-2		MR-1	
		Peak	Design	Peak	Design	Peak	Design
A) Loose Fine Sands, Alluvium; Soft Clays Varied Clays, Fill	4 - 8	3-5K	2K	5-8K	4K	8-12K	6K
B) Loose to Medium Dense Fine to Coarse Sands; Firm to Stiff Silts and Clays	7 - 14	5-8K	4K	7-10K	5K	10-15K	8K
C) Med Dense Coarse Sand and Sandy Gravel; Stiff to Very Stiff Silts and Clays	14 - 25	7-9K	5K	9-12K	7K	15-20K	11K

- Assumed design value is peak capacity range average divided by FS=1.5
- Test anchors shall be proofloaded to failure in actual site soils to confirm peak holding capacity.
- Anchors shall be proofloaded or "locked" to their design load to validate each soil/anchor capacity.
- All manufacturer's installation recommendations of Manta Ray by Foresight Products shall be followed.

**Typical Keystone/Manta Ray Anchor Sizing and Lengths**

**11.67' Design Height Example**

Minimum Anchor Lengths			
Designation	A-Soil	B-Soil	C-Soil
L1	13'	12'	12'
L2	11'	10'	10'
L3	8'	8'	8'

Minimum Anchor Sizes			
Level Backslope			
Designation	A-Soil	B-Soil	C-Soil
A1	MR-2	MR-3	MR-3
A2	MR-1	MR-2	MR-3
A3	Exceeds Pipe & Anchor Cap	MR-2	MR-2

Level - 250 psf Surcharge			
Designation	A-Soil	B-Soil	C-Soil
A1	Requires Site Specific Analysis	MR-2	MR-3
A2		Exceeds Pipe Capacity	MR-2
A3		Exceeds Pipe Capacity	MR-2

3H:1V Backslope			
Designation	A-Soil	B-Soil	C-Soil
A1	MR-2	MR-3	MR-3
A2	Exceeds Pipe & Anchor Cap	MR-2	MR-3
A3	Exceeds Pipe & Anchor Cap	MR-1	MR-3

**8.33' Design Height Example**

Minimum Anchor Lengths			
Designation	A-Soil	B-Soil	C-Soil
L1	-	-	-
L2	11'	10'	10'
L3	8'	8'	8'

Minimum Anchor Sizes			
Level Backslope			
Designation	A-Soil	B-Soil	C-Soil
A1	-	-	-
A2	MR-2	MR-3	MR-3
A3	MR-1	MR-2	MR-3

Level - 250 psf Surcharge			
Designation	A-Soil	B-Soil	C-Soil
A1	Requires Site Specific Analysis	-	-
A2		MR-2	MR-3
A3		MR-1	MR-2

3H:1V Backslope			
Designation	A-Soil	B-Soil	C-Soil
A1	-	-	-
A2	MR-2	MR-3	MR-3
A3	MR-1	MR-2	MR-3

A-Soil --  $\phi = 26^\circ$  and  $\gamma = 120$  pcf assumed  
 B-Soil --  $\phi = 30^\circ$  and  $\gamma = 120$  pcf assumed  
 C-Soil --  $\phi = 34^\circ$  and  $\gamma = 120$  pcf assumed

COPYRIGHT (c) 2000 by Keystone Retaining Wall Systems, Inc.

The information contained herein has been compiled by Keystone Retaining Wall Systems and to the best of our knowledge, accurately represents the Keystone product use in the applications which are illustrated. This drawing is being furnished for design guidance and estimating only. Final determination of the suitability for the use contemplated and its manner of use are the sole responsibility of the user. Structural and geotechnical design analysis shall be performed by a qualified engineer.

Any party accepting this document does so in confidence and agrees that it shall not be duplicated in whole or in part, nor disclosed to others without the consent of Keystone Retaining Wall Systems, Inc.

No.	Date	Revision	By



Designed By:  
cdm  
Checked By:  
Date:  
6/29/00

Keystone/Manta Ray Wall

Keystone/Manta Ray Design

Project No: Drawing No. 4

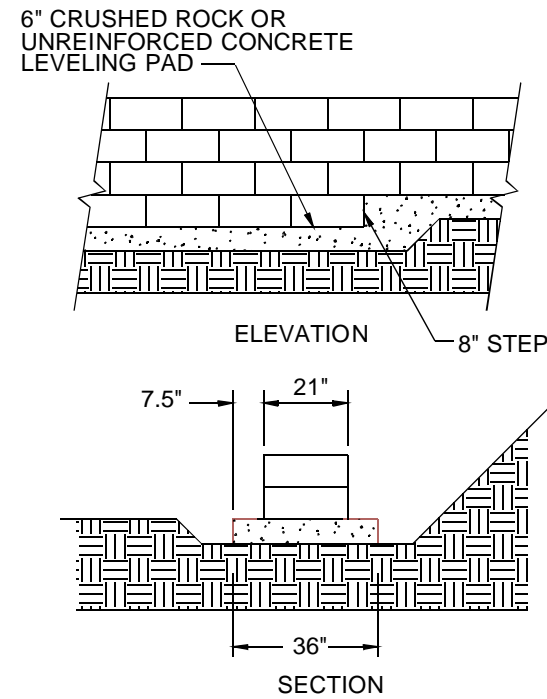

LEVELING PAD DETAIL

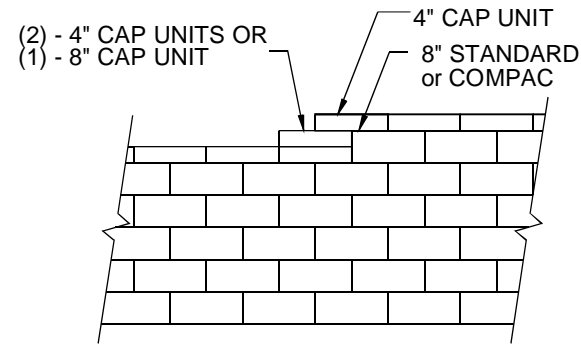

TOP OF WALL STEPS

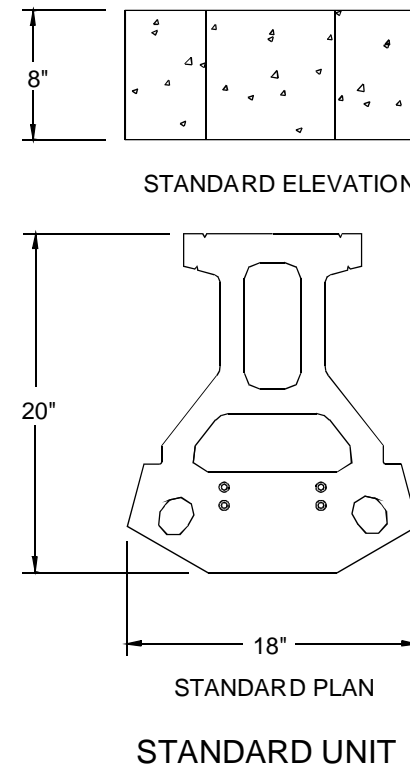

STANDARD UNIT

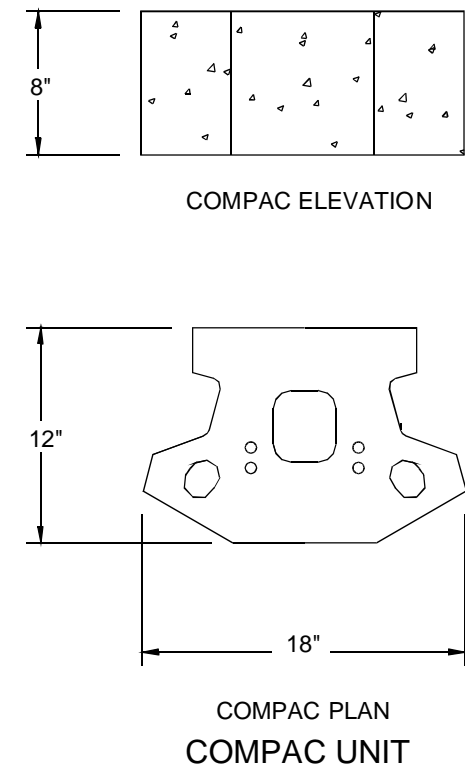

COMPAC UNIT

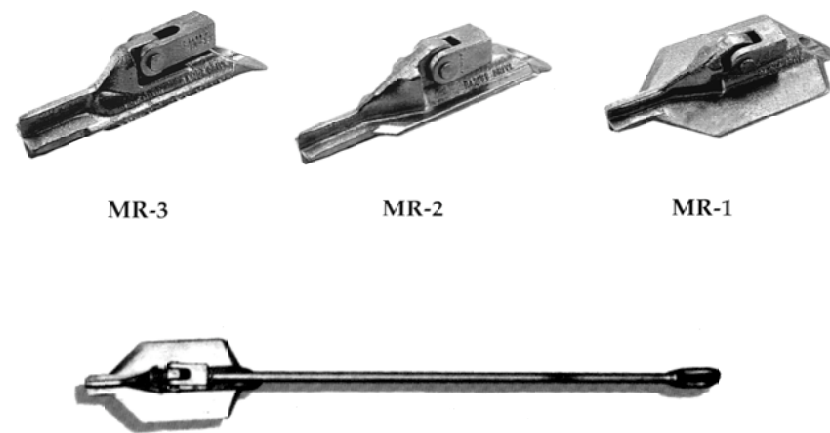

MANTA RAY ANCHORS



MANTA RAY INSTALLATION EQUIPMENT

COPYRIGHT (c) 2000 by Keystone Retaining Wall Systems, Inc.

The information contained herein has been compiled by Keystone Retaining Wall Systems and to the best of our knowledge, accurately represents the Keystone product use in the applications which are illustrated. This drawing is being furnished for design guidance and estimating only. Final determination of the suitability for the use contemplated and its manner of use are the sole responsibility of the user. Structural and geotechnical design analysis shall be performed by a qualified engineer.

Any party accepting this document does so in confidence and agrees that it shall not be duplicated in whole or in part, nor disclosed to others without the consent of Keystone Retaining Wall Systems, Inc.

No.	Date	Revision	By



Designed By:  
cdm  
Checked By:  
Date:  
6/29/00

Keystone/Manta Ray Wall

Typical Details  
Project No:  
Drawing No. 5

**Specification Guidelines**

**Part 1: General**

1.01 Description

- A. Work includes furnishing and installing a KEYSTONE retaining wall with Manta Ray earth anchors to the lines and grades shown on the construction drawings and as specified herein.
- B. Work includes preparing foundation soil, furnishing and installing leveling pad, furnishing and installing Manta Ray earth anchors, unit drainage fill and backfill to the lines and grades shown on the construction drawings.
- C. Work includes furnishing and installing all related materials required for construction of the retaining wall as shown on the construction drawings.

1.02 Reference standards

- A. ASTM C1372 Segmental Retaining Wall Units
- B. ASTM A536 Ductile Iron Castings
- C. ASTM A615 Deformed and Plain Billet-Steel Bars
- D. ASTM A53 Pipe, Steel, Black and Hot-Dipped, Zinc-Coated, Welded and Seamless
- E. ASTM A123 Zinc (Hot Dip) Coatings on Iron and Steel Products
- F. ASTM A153 Zinc (Hot Dip) Coatings on Iron and Steel Hardware
- G. ASTM D448 Sizes of Aggregate for Road and Bridge Construction.
- H. ASTM D698 Laboratory Compaction Characteristics using Standard Effort.

1.03 Quality assurance

- A. Owner will be responsible for soil testing and inspection quality control during earthwork operations.

**Part 2: Materials**

2.01 Definitions

- A. Concrete Units - a KEYSTONE modular concrete facing unit, machine made from portland cement, water and mineral aggregates.
- B. Structural Geogrid - a structural geogrid formed by a regular network of integrally connected tensile elements with apertures of sufficient size to allow interlocking with surrounding soil, rock, or earth and function primarily as reinforcement.
- C. Unit Fill - drainage aggregate which is placed within and immediately behind the modular concrete units.
- D. Earth Anchor - a galvanized Manta Ray earth anchor assembly and tie rod to connect Keystone facing units to earth retention system.

2.02 KEYSTONE units

- A. KEYSTONE wall units shall have a minimum 28-day compressive strength of 3,000 psi. Standard weight concrete shall have a maximum moisture absorption of 8%.

2.03 Manta Ray Anchors

- A. Manta Ray anchors shall consist of galvanized iron anchor/shackle assemblies, galvanized thread bar assemblies, and galvanized pipe loop connectors.

2.04 Fiberglass connecting pins

- A. Connecting pins shall be 1/2" diameter thermoset isophthalic polyester resin-pultruded fiberglass reinforcement rods supplied

by the unit manufacturer.

2.05 KEYSTONE KapSeal™ construction adhesive

- A. Material shall conform to ASTM 2339 and shall be supplied by the KEYSTONE unit supplier.

2.06 Geogrid

- A. Geogrid shall be the type as shown on the drawings having the property requirements described within the manufacturer's specifications and required by the design.

2.07 Base leveling and pad material

- A. Material shall consist of compacted crushed stone or unreinforced concrete as shown on the construction drawings.

2.08 Unit Drainage Fill

- A. Unit drainage fill shall consist of clean 1" minus crushed stone or crushed gravel meeting the following gradation:

Sieve Size	% Passing
1 inch	100
3/4"	75-100
No. 4	0-10
No. 50	0-5

2.09 Retained Soils

- A. Retained soils shall be inspected by a geotechnical engineer and test anchors proofloaded to failure to establish anchor holding capacity and stability of retained soils prior to wall installation.

**Part 3: Execution**

3.01 Excavation

- A. Contractor shall excavate to the lines and grades shown on the construction drawings. Contractor shall be careful not to disturb embankment and foundation materials beyond lines shown.

3.02 Foundation soil preparation

- A. Foundation soil shall be excavated as required for leveling pad dimensions shown on the construction drawings, or as directed by the Engineer.
- B. Unsuitable soils shall be removed and replaced with acceptable material.
- C. Over-excavated areas shall be backfilled with approved compacted backfill material.

3.03 Base leveling pad

- A. Leveling pad materials shall be placed upon an approved foundation as shown on the construction drawings to a minimum thickness of 6".
- B. Aggregate material shall be compacted to provide a dense, level surface on which to place the first course of modular units. Compaction shall be to 95% of Standard Proctor Density as determined in accordance with ASTM D698. For crushed rock, material shall be densely compacted as determined by visual observation.

3.04 Anchor Installation

- A. Anchors shall be installed at the locations required by the design layout.
- B. Anchors shall be of the type, size, and length specified by the design.
- C. Anchor installation and proofloading shall be performed in accordance with the detailed instructions and with equipment recommended by Foresight Products, LLC.

- D. Wall facing connection hardware shall be installed after anchor installation is complete and tested.

3.05 Unit installation

- A. The first course of concrete modular wall units shall be carefully placed on the base leveling pad. Each unit shall be checked for level and alignment.
- B. Units are placed side by side for full length of wall alignment. Alignment may be done by means of a string line or offset from a base line.
- C. Install fiberglass connecting pins and fill all voids in and around the modular units with unit fill material. Tamp or rod unit fill to insure that all voids are completely filled.
- D. Sweep excess material from top of units and install the next course. Ensure that each course is completely unit filled, backfilled and compacted prior to proceeding to next course.
- E. Place each subsequent course ensuring that pins protrude into adjoining courses a minimum of 1". Two pins are required per unit. Pull each unit forward, away from the fill zone, locking against the pins in the previous course and backfill as the course is completed. Repeat procedure to the extent of wall height.

3.06 Anchor connection/ geogrid installation

- A. Geogrid and pipe connection material shall be placed at the proper elevations and orientation as shown on the construction drawings or as directed by the Engineer.
- B. Correct orientation (roll direction) of the geogrid shall be verified by the contractor.
- C. The geogrid soil reinforcement shall be connected to the KEYSTONE wall units by placing the geogrid over fiberglass pins and laying the grid back under the anchor connection pipe and up the soil bank.
- D. The geogrid shall be pulled taut (50lbs/ft±) to eliminate loose folds and pretension the reinforcement. Secure the edge of geogrid prior to backfill and compaction of the unit fill between the unit and connection pipe assembly.
- E. After the geogrid and pipe are backfilled, the geogrid is returned to the wall facing and connected to the next course level.

3.07 Cap installation

- A. Place KEYSTONE Cap units over projecting pins from units below. Pull forward to setback position. Backfill and compact to finished grade with low permeability soil.
- B. As required, provide permanent mechanical connection to wall units with KEYSTONE KapSeal™ construction adhesive. Apply adhesive to top surface of unit below and place cap unit into position.

COPYRIGHT (c) 2000 by Keystone Retaining Wall Systems, Inc.

The information contained herein has been compiled by Keystone Retaining Wall Systems and to the best of our knowledge, accurately represents the Keystone product use in the applications which are illustrated. This drawing is being furnished for design guidance and estimating only. Final determination of the suitability for the use contemplated and its manner of use are the sole responsibility of the user. Structural and geotechnical design analysis shall be performed by a qualified engineer.

Any party accepting this document does so in confidence and agrees that it shall not be duplicated in whole or in part, nor disclosed to others without the consent of Keystone Retaining Wall Systems, Inc.

No.	Date	Revision	By



Designed By:  
cdm

Checked By:

Date:  
6/29/00

Keystone/Manta Ray Wall

General Notes

Project No:

Drawing No.